

AMERICAN RANGE

Quality Commercial Cooking Equipment

www.americanrange.com

AF45 HEAVY DUTY DEEP FAT FRYERS

You get a faster and better fryer from AMERICAN RANGE. With the latest technology incorporated into its design, and tons of features and benefits to suit the everyday demanding needs especially during extreme operating periods. Bringing added value and assured performance, by offering the highest BTU rating for superior recovery. The ample "cool zone" prevents food particles from carbonization while extending oil life. Our unique vessel tank design features a deeper oil level, for larger food products, and a sloping vessel bottom for quick and complete draining of oil and debris. Its special design tube shields provide a uniform heating pattern for positive, more consistent frying results. Equipped with a Millivolt Control System, and a 100% safety shut off valve. No electrical power is required. Conveniently located controls for easy access for operators, maintenance and service. All stainless steel heavy duty exterior construction, with a durable double panel door, rugged base and removable stainless steel basket guide. Equipped with two nickel plated baskets having cool grip plastic coated handles, to provide maximum operator comfort.



SHOWN WITH
OPTIONAL
CASTERS



NSF

AF45



STANDARD FEATURES

- Stainless steel heavy duty construction.
- Extra depth oil level for frying larger products.
- Front slanting vessel bottom for quick and easy draining of oil and debris.
- Ample "cool zone" prevents trapped food particle carbonizations while extending oil life.
- Highest BTUs for instant recovery at extreme peak periods.
- Rugged double layer access door.
- Thermostatic control from 200 - 400 degrees F.
- Millivolt System with 100% safety shut off. No electrical power required.

OPTIONS

- Stainless steel cover.
- Casters (4 with 2 locking).
- Matching "Dump Station".
- Quick disconnect and flexible gas hose.

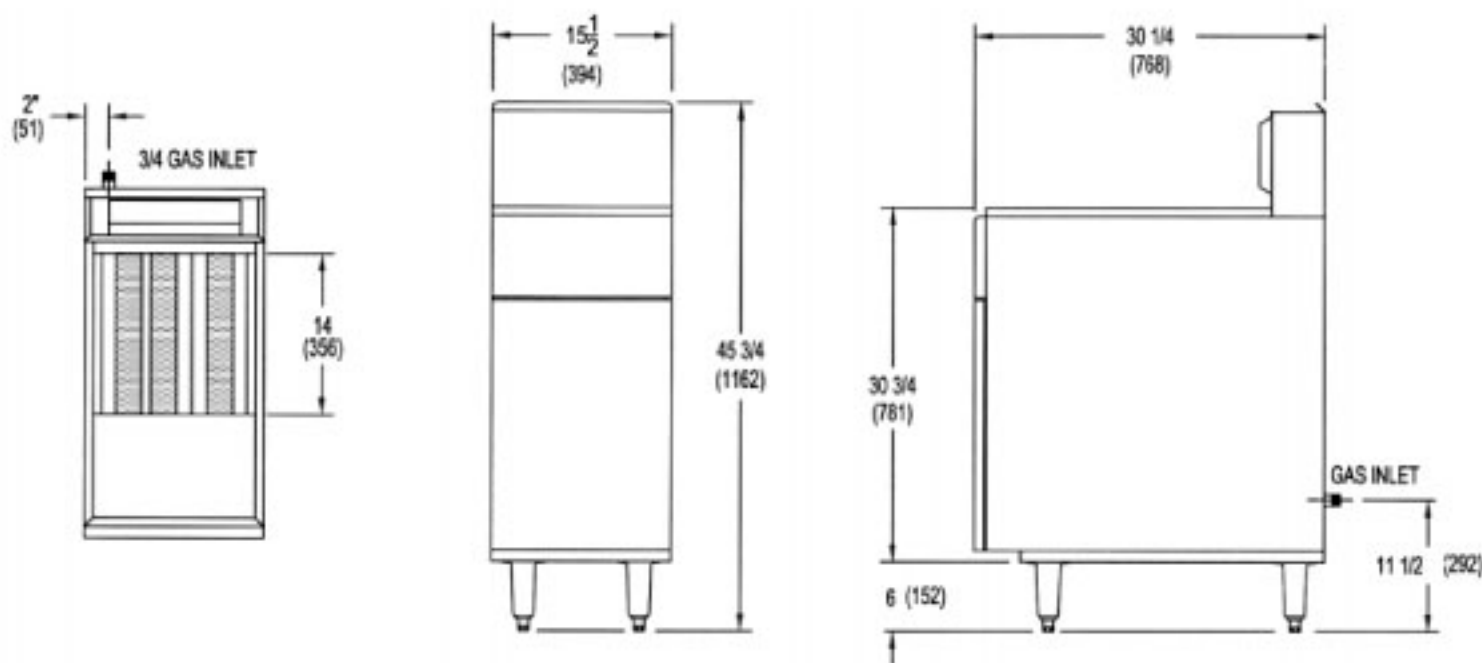

HEAVY DUTY DEEP FAT FRYER

Oil Capacity Lbs. (liters)	Total BTU	KW	width (mm)	depth (mm)	Overall height	Cooking Area	No. of Burners	Ship Weight:	lbs.	Kg.
			ONE POT				STAINLESS STEEL FRYPOT			
AF-45 35lbs. - 50lbs. (19-27)	120,000	35.17	15 1/2" (394)	30 1/4" (768)	45 3/4" (1162)	14" x 14" (356 x 356)	3		220	100
			SPLIT POT				STAINLESS STEEL FRYPOT			
AF-2545 (1) 20lbs. - 30lbs. (11-16) (1) 35lbs. - 50lbs. (19-27)	200,000	58.62	23 1/4" (591)	30 1/4" (768)	45 3/4" (1162)	(1) 6 3/4" x 14" (172 x 356) (1) 14" x 14" (356 x 356)	5		350	158

FEATURES

- Fryer vessel tank: All stainless Steel high quality construction, 16 ga. #304 material
- Exterior: All Stainless Steel front, sides, door and basket hanger/flue riser.
- S/S Door: Durable double layer access door
- Basket Hanger: Removable basket hanger accommodates two fryer baskets (AF-45).
- Fryer Baskets: Twin chrome plated fryer baskets with cool grip plastic coated handles for operator safety and ease (AF-45).
- Millivolt control system: No electrical hook up required.
- Thermostatic Control: Thermostat adjusts from 200°F to 400°F.
- Safety shut off System: 100% gas shut off when temperature reaches the hi-limit.
- Combination Gas Valve: Includes pressure regulator and pilot ignition system, hermetically sealed for operating stability, 3/4" N.P.T gas inlet in rear.
- Crumb Screen: Large removable tight mesh nickel plated screen under fryer baskets.
- Drain Valve: 1 1/4" (32) diameter for easy draining of oil. Plastic coated handle for safety.
- Legs: 6" (152) high chrome plated adjustable legs.
AGA/CGA Design certified and NSF Listed.

OPTIONS

- Casters: 6" (152) high casters, front two with locking brakes.
- Vessel Cover: Stainless Steel cover to fit over fryer vessels.
- Joiner Strip: To connect two fryers and prevent oil seepage between the fryers or drain station.
- Quick Disconnect: Gas Hose with restraining device for added safety.
- Dump Station: Stainless Steel dump station with door and convenient cabinet below.

Gas: Manifold pressure is 4" W.C. for natural gas or 11" W.C. for propane gas. Specify type of gas and altitude if over 2000 feet. 3/4" NPT Gas Inlet.
Clearances: For installation on combustible floors using 6" (152) legs or casters. Clearance to combustible walls 6" sides and rear. 0" to non-combustible wall.

American Range Corporation is a quality manufacturer of commercial cooking equipment. Because of continuing product improvements these specifications are subject to change without prior notice.